

Russell Taylors

E-WARRANTY



SCAN HERE

AIR FRYER

USER MANUAL

www.russelltaylors.co.uk

Z4



For warranty claims, please submit an email to

malaysia@russelltaylors.com together with your order number or a

copy of your invoice. This product is backed by a 2-year warranty

IMPORTANT SAFEGUARDS

When using electrical appliances, basic safety precautions should always be followed including the following:

1. Read all of the instructions provided.
2. Do not touch hot surfaces.
3. To protect yourself against electric shock do not immerse cord, plugs, or base in water or other liquid.
4. **WARNING:** This electrical appliance contains a heating function. Surfaces, also different than the functional surfaces, can develop high temperatures. Since temperatures are differently perceived by different persons, this equipment shall be used with **CAUTION**. The equipment shall be touch only at intended handles and gripping surfaces, and use heat protection like gloves or anything similar. Surfaces other than the intended gripping surfaces shall get sufficient time to cool down before being touched.
5. Unplug from the outlet when not in use and before cleaning. Allow time to cool before putting on or taking off parts.
6. If the supply cord is damaged, it must be replaced by the manufacturer, its service agent or similarly qualified persons in order to avoid a hazard.
7. The use of accessory attachments not recommended by the appliance

manufacturer may cause injuries.

8. Do not use outdoors.
9. Do not let the cord hang over the edge of the table or counter, or touch hot surfaces.
10. Do not place on or near a hot gas or electric burner, or in a heated oven.
11. Extreme caution must be used when moving an appliance containing hot oil or other hot liquids.
12. Do not use appliance for other than intended use.
13. This appliance can be used by children aged from 8 years and above and persons with reduced physical, sensory or mental capabilities or lack of experience and knowledge if they have been given supervision or instruction concerning the use of the appliance in a safe way and understand the hazards involved. Children shall not play with the appliance. Cleaning and user maintenance shall not be made by children unless they are old than 8 and supervised.
14. Keep the appliance and its cord out of reach of children less than 8 years.
15. The appliances are not intended to be operated by means of an external timer or separate remote-control system.

SAVE THESE INSTRUCTIONS

This appliance is intended to be used in a household environment only. Any evidence of commercial usage will result in a void of warranty.

General description (Fig.1&2)

- | | |
|------------------|--------------------------------|
| 1. Display panel | 2. Rack |
| 3. Handle | 4. Pot cover |
| 5. Main housing | 6. Frying Pot |
| 7. Air outlet | 8. Main cord (Electrical cord) |

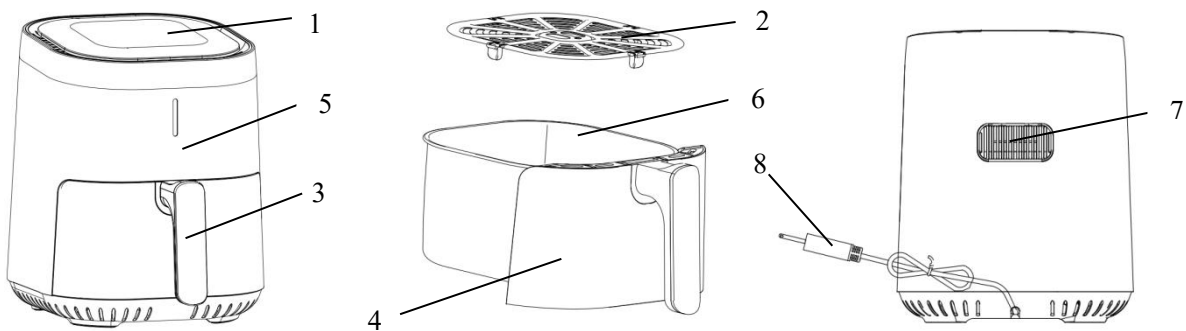

Fig.1



Fig.2

BEFORE FIRST USE

1. Remove all packaging materials.
2. Remove any stickers or labels from the appliance.

3. Thoroughly clean the basket and pot with hot water, some washing-up liquid and a non-abrasive sponge.
4. Wipe inside and outside the appliance with a moist cloth.

This is an oil-free fryer that works on hot air, do not fill the pot with oil or frying fat directly.

Notice: When your air fryer is heated for the first time, it may emit smoke or odor. This is normal with many heating appliances. This does not affect the safety of your appliance.

PREPARING FOR USE

1. Place the appliance on a stable, horizontal and even surface.

Do not place the appliance on non-heat-resistant surface.

2. Place the basket into the pan .

Do not fill the pan with oil or any other liquid.

Do not put anything on top of the appliance, the airflow will be disrupted and affects the hot air frying result.

USING THE APPLIANCE

The oil-free can prepare a large range of ingredients.

Hot air frying

1. Connect the mains plug into an earthed wall socket.
2. Carefully pull the pan out of the Hot-air fryer.
3. Put the ingredients in the basket.
4. Slide the pan back into the Hot-air fryer.

Noting to carefully align with the guides in the body of the fryer.

Never use the pan without the basket in it.

Caution: Do not touch the pan during and sometime after use, as it gets very hot.

Only hold the pan by the handle.

5. Determine the required preparation time for the ingredient.
6. Some ingredients require shaking halfway through the preparation time. To shake the ingredients, pull the pan out of the appliance by the handle and shake it. Then slide the pan back into the fryer.
7. When you hear the timer buzzer, the set preparation time has elapsed. Pull the pot out of the appliance

Note: You can also switch off the appliance manually. Just long press the power button for 3 seconds

8. Check if the ingredients are ready. If the ingredients are not ready yet, simply slide the pot back into the appliance and set the timer to a few extra minutes.

Do not turn the basket upside down with the pot still attached to it, as any excess oil that has collected on the bottom of the pot will leak onto the ingredients. The pot and the ingredients are hot. Depending on the type of the ingredients in the air fryer, steam may escape from the pot.

9. Empty the basket into a bowl or onto a plate.
10. When a batch of ingredients is ready, the air fryer is instantly ready for preparing another batch.

CONTROL PANEL

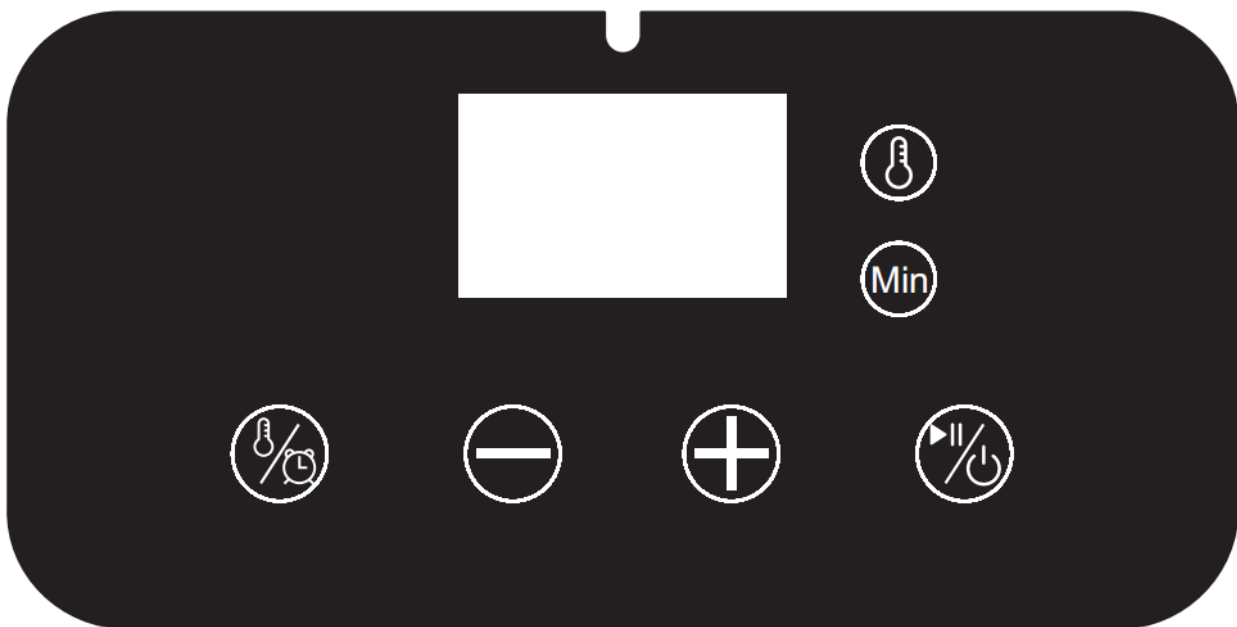

Operation Instructions:

 Used for adding and subtracting temperature and time.

 Temperature and time switching.

 Used to turn on/off.

Settings

This table below will help you select the basic settings for the ingredients.

Note: Keep in mind that these settings are indications. As ingredients differ in origin,

size, shape as well as brand, we cannot guarantee the best setting for your ingredients.

Tips

- Smaller ingredients usually require a slightly shorter preparation time than larger ingredients.*
- A larger amount of ingredients only requires a slightly longer preparation time, a smaller amount of ingredients only requires a slightly shorter preparation time.*
- Shaking smaller ingredients halfway through the preparation time optimizes the end result and can help prevent unevenly fried ingredients.*
- Add some oil to fresh potatoes for a crispy result. Fry your ingredients in the air fryer a few minutes after you added the oil.*
- Do not prepare extremely greasy ingredients such as sausages in the air fryer .*
- Snacks that can be prepared in an oven can also be prepared in the air fryer*
- The optimal amount for preparing crispy fries is 500 grams.*
- Use pre-made dough to prepare filled snacks quickly and easily. Pre-made dough also requires a shorter preparation time than home-made dough.*
- Place a baking tin or oven dish in the air fryer basket if you want to bake a cake or quiche or if you want to fry fragile ingredients or filled ingredients*
- You can also use the air fryer to reheat ingredients. To reheat ingredients, set the temperature to 150°C for up to 10 minutes.*

	Amount (g)	Time (min)	Temperature	Shake	Extra information
Frozen French fries	500-600	23-27	180-200°C	shake	
Chicken wings	600-800	23-27	180-200°C		
Drumsticks	600-800	23-27	180-200°C		
Fish	500-600	18-22	180-200°C		
Shrimp	400-500	18-22	150-170°C		
Biscuits	140-160	13-17	160-180°C		
steak	160-200	18-22	160-180°C		
Cake	120-160	14-16	160-180°C		

Note:

1. Add 3 minutes to the preparation time when you start frying while the air fryer is still cold.

2. Turn or shake once during baking

CLEANING

Clean the appliance after every use.

Do not use metal kitchen utensils or abrasive cleaning materials to clean the pot and the non-stick basket, as this may damage the non-stick coating.

1. Remove the main plug from the wall socket and let the appliance cool down.

Note: Remove the pot to let the air fryer cool down more quickly.

2. Wipe the outside of the appliance with a moist cloth.
3. Clean the pot and basket with hot water, some washing-up liquid and a non-abrasive sponge.

You can use degreasing liquid to remove any remaining dirt.

Tip: If dirt is stuck to the basket or the bottom of the pot, fill the pot with hot water with some washing-up liquid. Put the basket in the pot and let the pot and the basket soak for approximately 10 minutes.

4. Clean the inside of the appliance with hot water and non-abrasive sponge.
5. Clean the heating element with a cleaning brush to remove any food residues.

STORAGE

1. Unplug the appliance and let it cool down.
2. Make sure all parts are clean and dry.

point for recycling. By doing this, you help to preserve the environment

TROUBLESHOOTING

problem	Possible cause	Solution
The air fryer does not work	The appliance is not plugged in.	Put the mains plug in an earthed wall socket.

	You have not set the timer.	Set the timer key to the required preparation time to switch on the appliance.
The ingredients fried with the air fryer are not done.	The amount of ingredients in the basket is too big.	Put smaller batches of ingredients in the basket. Smaller batches are fried more evenly.
	The set temperature is too low.	Set the temperature key to the required temperature setting (see section 'settings' in chapter 'Using the appliance').
	The preparation time is too short.	Set the timer to the required preparation time (see section 'Settings' in chapter 'Using the appliance').
The ingredients are fried unevenly in the air fryer.	Certain types of ingredients need to be shaken halfway through the preparation time.	Ingredients that lie on top of or across each other (e.g. fries) need to be shaken halfway through the preparation time. See section 'Settings' in chapter 'Using the appliance'.
Fried snacks are not crispy when they come out of the air fryer.	You used a type of snacks meant to be prepared in a traditional deep fryer.	Use oven snacks or lightly brush some oil onto the snacks for a crispier result.
I cannot slide the pan into the appliance	There are too much ingredients in the basket.	Do not fill the basket beyond the MAX indication.

properly.	The basket is not placed in the pot correctly.	Push the basket down into the pot until you hear a click.
White smoke comes out of the appliance.	You are preparing greasy ingredients.	When you fry greasy ingredients in the air fryer, a large amount of oil will leak into the pot. The oil produces white smoke and the pot may heat up more than usual. This does not affect the appliance or the end result.
	The pot still contains grease residues from previous use.	White smoke is caused by grease heating up in the pan. Make sure you clean the pan properly after each use.
Fresh fries are not crispy when they come out of the air fryer.	The crispiness of the fries depends on the amount of oil and water in the fries.	Make sure you dry the potato sticks properly before you add the oil.
		Cut the potato sticks smaller for a crispier result.
		Add slightly more oil for a crispier result.